

D. N. HYLAN & ASSOCIATES, INC.

BOATBUILDERS

CAM KIT FOR POINT COMFORT 18 DEADRISE SKIFF

This kit provides the plywood pieces necessary to complete the hull of this boat. In most cases, these pieces are cut to the necessary shape, but the planking in the forefoot area is provided as 4 x 8 sheets as it is necessary to make this part of the hull from several small pieces. It is difficult to derive the shape of these pieces on my available software, but it's quite easy to do it in the shop.

As it is so expensive to ship long pieces of wood, you will need to purchase the solid lumber in your area. For the setup, some 2-by stock from your local lumber yard will do, but you may have to go farther afield for the higher quality solid lumber that goes into the hull. Most areas are served by hardwood suppliers that will carry this lumber – the internet or a local cabinet shop should be able to help with this.

Your kit will contain two categories of pieces: those that go into the setup (temporary molds, ladder frame parts) and those that go into the boat itself (BS1088 Standard marine meranti plywood.) If there is no supplier for marine plywood in your area, additional sheets for the non-hull parts of the boat (seats, bulkheads, motorwell, deck, etc.) can be ordered with the kit. This can be cost effective, as the extra weight will not add greatly to the shipping costs.

The attached drawing shows the parts that will come with your kit as well as how the assembled setup will look. A full scale and more detailed version of this drawing will come with your kit. For pieces longer than 8', pieces will come with scarf joints milled in them, to be glued to full length in your shop. A template is included to assist in making a jig to hold the scarfs in proper alignment.

Molds will come scribed with the station number, centerline and DWL. The ladder frame parts are designed to help insure quick spacing and centering of the molds and alignment the stem and transom. The stem and transom pieces are scribed with alignment marks to assist with proper setup.

ORDERING KITS: Hewes & Co., Marine Division, Blue Hill, Maine handles the manufacture and selling of our kits. Please see their web site, www.cnc-marine-hewesco.com, for ordering information and current pricing.

Kits will ship on a 4' x 8' pallet. Contact Hewes & Co. for shipping costs. Shipping costs can be reduced by arranging shipment to a commercial location, usually defined as one have a loading dock or fork truck available. Please allow four weeks from date of order to delivery.

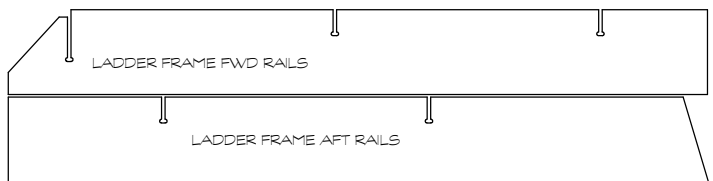
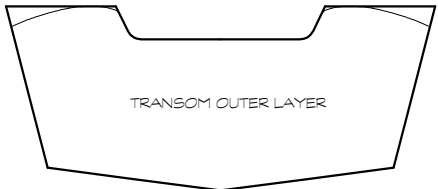
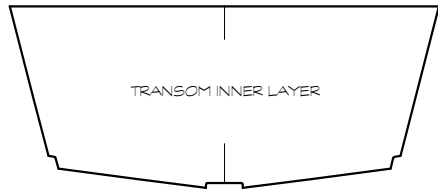
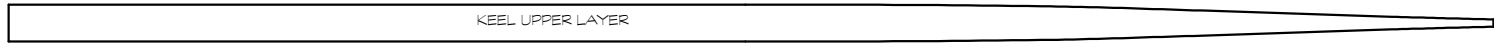
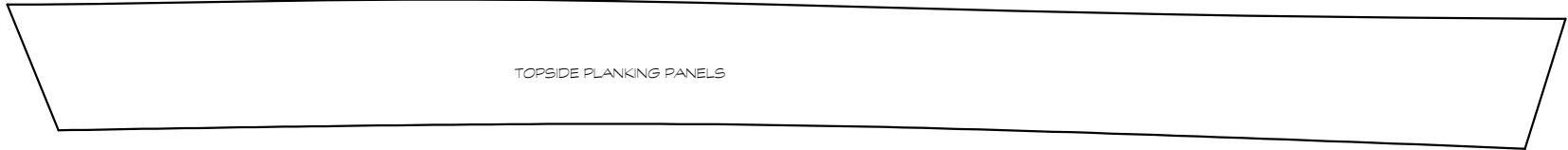

TEMPORARY MOLD PARTS

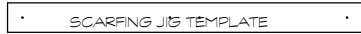

PERMANENT BOAT PARTS

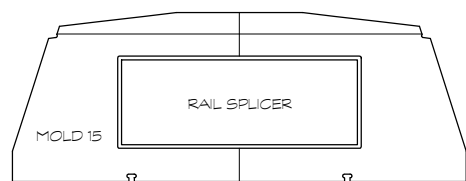
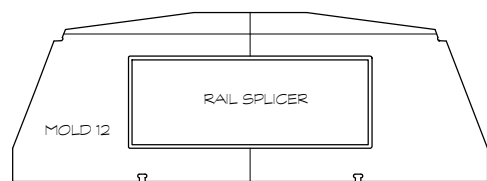
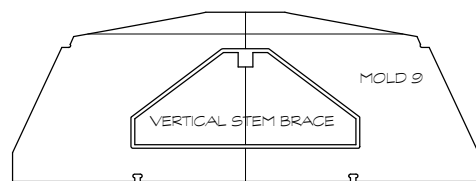
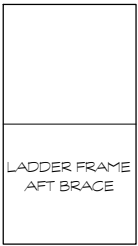
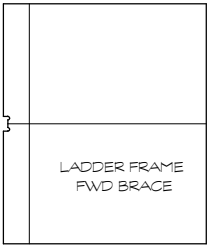
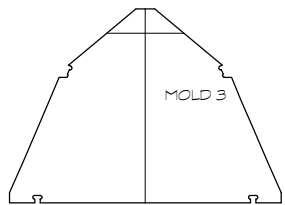
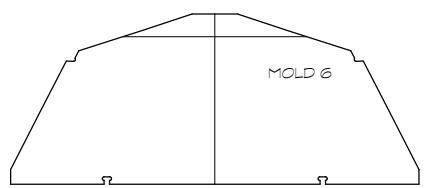
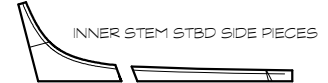

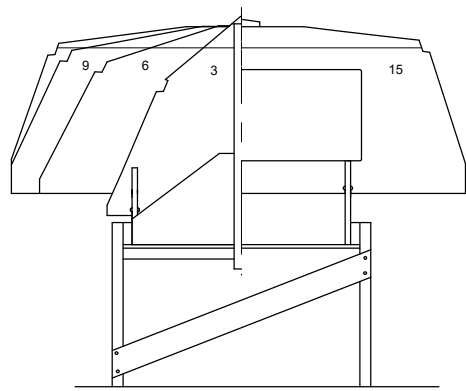
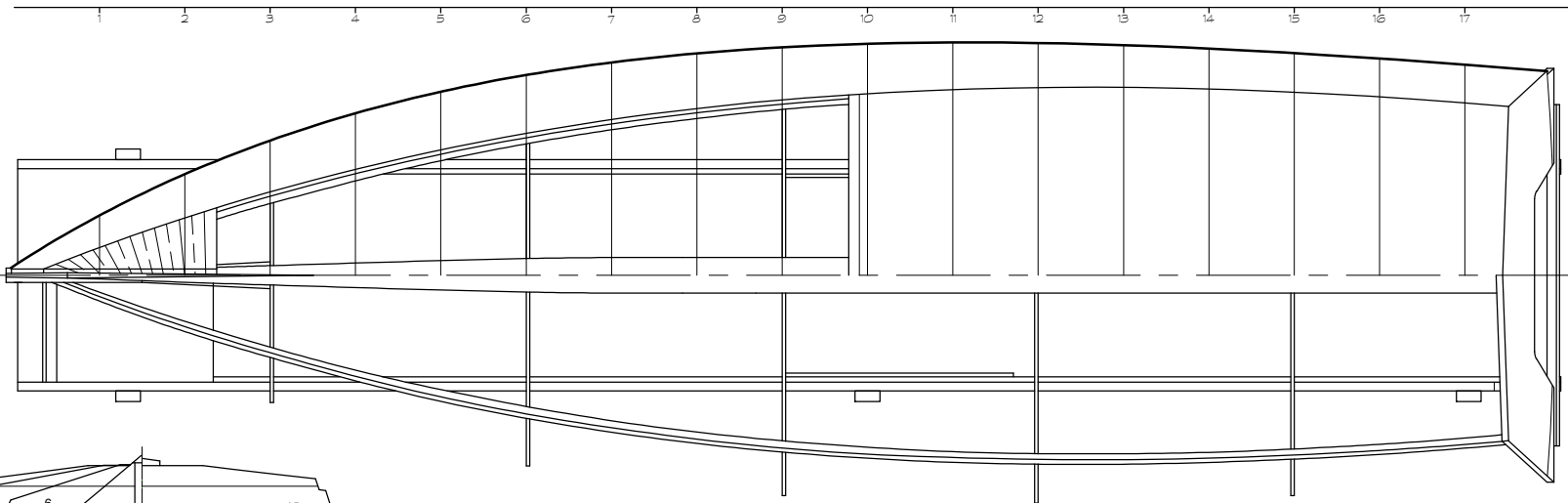

SET UP NOTES

FOR REINFORCING THE LADDER FRAME RAILS YOU WILL NEED TWO 18 FOOT PIECES OF 2 X 4. THESE PIECES SHOULD BE AS STRAIGHT AND FREE FROM TWIST AS POSSIBLE. SO SELECT STOCK CAREFULLY AT THE LUMBER YARD. AS SHOWN, THE RAILS ARE FINISHED AT 1 1/2" X 3" TO ALLOW FOR STRAIGHTENING THESE PIECES, IF NECESSARY, SCARP OR BRUCE TO GET THE NECESSARY 18 LENGTH.

BRUCE THE TWO ENDS OF EACH LADDER FRAME RAIL TOGETHER USING THE RAIL BRUCE PIECES. BE CAREFUL THAT EACH RESULTING RAIL IS STRAIGHT. FASTEN THE BOW AND STERN BRACES TO THE BOTTOM OF THE 1 1/2" X 3" PIECES, THEN FASTEN THE BRUCE RAILS TO THE INSIDE OF THEM. USING HORSES OR 2-BY 4S, PROP THE LADDER FRAME UP TO A CONVENIENT WORKING HEIGHT. SHIM AND BRACE AS NECESSARY SO THAT THE LADDER FRAME IS STRAIGHT AND LEVEL, HAS NO TWIST, AND IS REASONABLY SOLID.

INSTALL THE MOLDS ONTO THE LADDER FRAME BY SLIDING THEM INTO THE MATING SLOTS IN THE TOP OF THE LADDER. BEFORE YOU PROCEED, CHECK ONE MORE TIME THAT EVERYTHING IS STRAIGHT, LEVEL, AND SQUARE TO INSURE THAT THE PRECUT PLANKING WILL FIT PROPERLY.

GLUE UP THE FOUR PLYWOOD INNER STEM PIECES, USING THE 3/8" HOLES TO INSURE ALIGNMENT. YOU CAN USE EITHER WOODEN DOWELS OR WAXED BOLTS IN THESE HOLES (YOU MAY NEED TO APPLY HEAT IN ORDER TO GET THE BOLTS OUT). MAKE SURE THE STEM ASSEMBLY IS FLAT BEFORE THE GLUE SETS. BEVEL THE SIDES OF THE INNER STEM, USING THE SCRIBED MARKS ON THE SIDES AND THE STEM FACE WIDTHS SHOWN ON THE FULL SIZE PATTERNS.

FASTEN TWO SOLID WOOD TRANSOM SUPPORTS TO THE AFT END OF THE PLYWOOD LADDER FRAME, AND INSTALL A GLEAT ACROSS THE TWO RAILS AT THE PROPER HEIGHT AS INDICATED BY THE SCRIBED LINES ON THE LADDER RAILS. GLUE UP THE TWO TRANSOM LAYERS AND MOUNT THE TRANSOM ON THE SETUP, SETTING IT ON TOP OF THE ABOVE GLEAT AND MAKING SURE THAT IT IS PROPERLY CENTERED. THE EDGES OF THE TRANSOM BLANK ARE MACHINED TO THE INSIDE (LARGER) FACE OF THE TRANSOM. THEY WILL NEED TO BE BEVELLED SO THAT THE PLANKING WILL LAND PROPERLY ON THEM.

INSTALL THE INNER STEM INTO THE SETUP, MAKING SURE IT IS VERTICAL AND USING THE NOTCHES IN THE FORWARD LADDER FRAME BRACE AND THE VERTICAL STEM BRACE TO HOLD IT THERE. ONCE THE INNER STEM, KEEL, AND CHINES HAVE BEEN GLUED UP, THE VERTICAL STEM BRACE IS REMOVED TO MAKE ROOM FOR THE TOPSIDE PLANKING. YOU WILL ALSO NEED TO WHITTLE AWAY A BIT OF THE FORWARD EDGE OF THE LADDER FRAME BRACE FOR THE SAME REASON.

GLUE UP THE SCARFED KEEL PIECES, CLEAN UP THE JOINTS AND MARK A CENTERLINE ON THE KEEL. TOP TO BE REGISTERED WITH THE CENTERLINE SCRIBED ON EACH MOLD. GLUE TOGETHER THE TWO KEEL LAYERS RIGHT IN PLACE ON THE SETUP. YOU WILL FIND IT NECESSARY TO FASTEN SMALL BLOCKS TO THE MOLDS IN NUMEROUS PLACES, TO BE USED FOR HOLDING VARIOUS PARTS IN PLACE (WITH EITHER CLAMPS OR TEMPORARY SCREWS) UNTIL GLUING IS COMPLETE.

PLYWOOD SCARFS FOR THIS KIT ARE ALIGNED BY MEANS OF A JOG CONSISTING OF FOUR 3/16" METAL PINS, MOUNTED IN A BENCH TOP OR PIECE OF PLYWOOD. A TEMPLATE IS INCLUDED WITH THE KIT TO USE AS A DRILLING JIG TO HELP INSURE ACCURATE PIN SPACING. THE PINS SHOULD PROTRUDE ABOVE THE WORK SURFACE ABOUT 2 1/2 TIMES THE THICKNESS OF THE PLYWOOD BEING SCARFED. IN USE, A PIECE OF PLASTIC FILM IS FITTED OVER THE CENTRAL PART OF THE WORK SURFACE TO MAKE SURE THE SCARFED PLANKS DO NOT STICK TO IT. THE SCARF JOINT SURFACES ARE COATED WITH GLUE AND FITTED DOWN OVER THE APPROPRIATE PINS. A SECOND PLANK PLANK SCARF MAY BE MADE AT THE SAME TIME WITH PLASTIC FILM BETWEEN THE PLANKS. FINALLY, A THIRD PIECE OF PLASTIC AND A FOLLOWER BOARD IS SET OVER THE TOP TO HELP DISTRIBUTE CLAMP PRESSURE.

